



MCM-20.4

PRELIMINARY USER GUIDE v1.0



© 2016 Heritage Audio S.L. is the sole owner of the copyright of all information and drawings contained in this manual which are not to be copied or reproduced by any means or disclosed in part or whole to any third party without written permission.

Heritage Audio reserves the right to alter specifications without notice. The information in this manual has been carefully checked and is believed to be accurate at the time of publication. However, no responsibility is taken by us for inaccuracies, errors or omissions nor any liability assumed for any loss or damage resulting either directly or indirectly from use of the information contained within it.

DESCRIPTION

The MCM-20.4 is a 20 x 4 channel summing mixer.

It employs a unique configuration, offering 20 input channels arranged as follows: 16 are implemented in 2 rows of 8 channels each, being the remaining 4 assigned to the master section, hard panned left and right in pairs. Unlike classic consoles employing a complicated switching matrix for subgroup assignment, the channels have a fixed-assignment in groups of eight. This arrangement not only makes the unit fit in a four-unit rack space, but greatly helps in making it affordable. Each channel features center detent Pan and Fader concentric controls plus balanced insert and mute switches.

The insert send points always have the signal present, so they can be alternatively used as direct outputs for recording without additional patch bays.

The 16 channels implemented on the front panel feature aux sends. A total of 4 different sends can be assigned, with a maximum of 2 per channel simultaneously. AUX 1 and 2 or 3ST can be assigned on a per channel basis, but not all 4 sends can be used on the same channel at the same time.

Each group has its own stereo fader and balanced insert point and all 4 stereo subgroups are passively summed into the master bus. The gain is restored by means of a 1073 style class A, transformer coupled, mic preamplifier, featuring a total of 4 transformers (2 in each channel).

The master section is also provided with its own balanced insert point.

All connections on the back are made by DSUB 25 connectors following the Tascam* protocol, with the exception of the master bus connections, which are by dedicated XLRs.

Comprising vintage quality sound with sophisticated routing options, the MCM20.4 is the perfect partner for hybrid setups, integrating analog gear with your DAW.

Lots have been written on the pros and cons between active (current) and passive (voltage) summing topologies. Some may claim one is better than the other but truth is active summing is less susceptible to noise and voltage, passive summing has a nice, vintage sound associated with its gain makeup circuit.

The smart hybrid summing topology used in the MCM20.4, where the channels are current-summed (active) into their corresponding subgroups and the subgroups voltage summed (passive) into the master section, has proven to give massive headroom and lower noise without making any compromises to its vintage characteristic sound.

FRONT PANEL OVERVIEW



The front panel is laid out in 4 rows, 2 of 8 channels each featuring grey knobs and 2 with blue knobs carrying the aux sends sections. Further right are the related subgroup controls and aux sends master faders.

Right side of the unit comprises the master section controls.

Controls per channel are as follows:

- ON: When pressed, the related input is added to the subgroup bus. When depressed, it's muted.
- INS: Turns the insert on. The insert send always have the signal present, whilst pressing the INS switch activates the insert return input.
- FADER: Attenuates the signal sent to the subgroup bus from unity to minus infinity. Fader all clockwise means unity gain, whilst 12 o'clock means an approximate 20 dB of attenuation. (Or -20dB of gain).
- PAN: Places the signal within the stereo spectrum, left, center, right or any intermediate setting. The panoramic law follows a standard in which if a 0dB signal is hard panned, it is -3dB when center panned.
- AUX SEND LEVEL AND / OR PAN: The aux sends are implemented on the blue concentric knobs below each channel. If AUX 1 and 2 are selected, inner knob is aux1 send and outer is aux 2 send, whilst having Aux 3 selected inner blue knob turns into stereo level and outer becomes pan.
- PRE: Takes the aux signal from the channel PRE or POST Fader.
- 3ST: Chooses between AUX 1 and 2 or 3ST.

Controls per Stereo subgroup are as follows:

- ON: When pressed, the output of the subgroup is sent to the Master bus. When depressed, it is muted.
- INS: Turns the insert on. The insert send always have the signal present, whilst pressing the INS switch activates the insert return input.

- **FADER:** Attenuates the signal sent to the Master bus from unity to minus infinity. The control has a stepped feel for easy recall of settings. Fader all clockwise means unity gain, whilst 12 o'clock means an approximate 20 dB of attenuation. (or -20dB of gain).

Controls for the Master Aux send levels are as follows:

- Master AUX 1 and 2 send level on a dual concentric control (inner for 1, outer for 2)
- Master AUX 3 send level on a Stereo control.

Right part of the unit is dedicated to the mixer's Master section, as follows:

- **VU Meters:** Measuring the average level at the master outputs. They are calibrated so 0VU = +8dBu.
- **Master Fader:** Attenuates the Mix's output from unity to minus infinity. The control has a stepped feel for easy recall of settings. Fader all clockwise means unity gain, whilst 12 o'clock means an approximate 20dB of attenuation.
- **ON:** When pressed, the output of the Master is sent to the Output connectors. When depressed, it is muted.
- **INS:** Turns the insert on. The insert send always have the signal present, whilst pressing the INS switch activates the insert return input.

BACK PANEL OVERVIEW



All the external connections are on the back panel, as follows:

- 5 pin XLR for the external HA-PSU02 power supply unit.
- XLRs for Mix Output L and R.
- XLRs for Monitor Output L and R
- XLRs (2) for Master Insert Send L and R
- XLRs (2) for Master Insert Return L and R
- DSUB 25 for Subgroup 1-4 Insert sends and Aux sends
- DSUB 25 for Subgroups 1-4 Insert Returns and Auxiliary inputs.
- DSUB 25 (2) for Channel Input 1-8, 9-16
- DSUB 25 (2) for Insert sends 1-8, 9-16
- DSUB 25 (2) for Insert Returns 1-8, 9-16

All XLRs are:

- Pin 1: GND
- Pin 2: Hot
- Pin 3: Cold

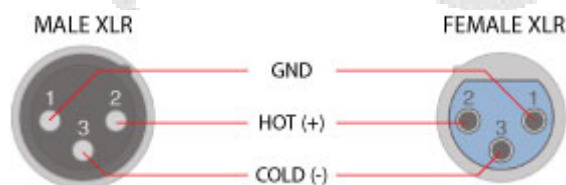

All DSUB 25 multi pin connectors are TASCAM protocol. This same protocol is also used by AVID* amongst many others, and is as follows:

Pin-out for TASCAM DB25 8 Channel Balanced Connector

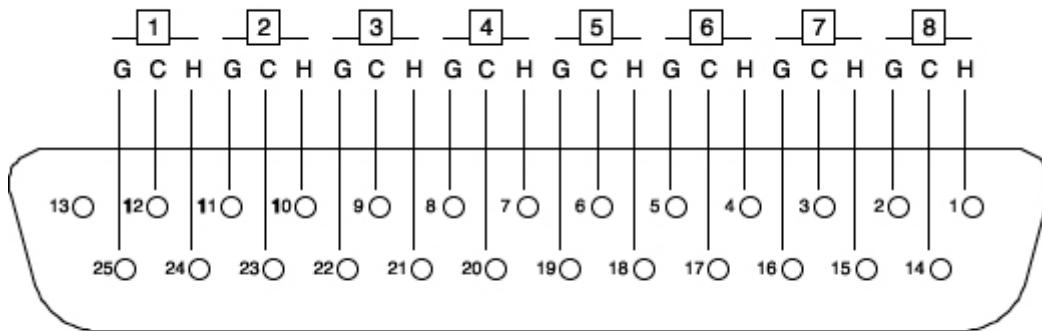

H = HOT
 C = COLD
 G = GROUND

The list of the DSUB connectors used and their corresponding channels are as follows:

CHANNEL INPUTS 1-8:

TASCAM DSUB CHANNEL #	CHANNEL I/P 1-8
1	INPUT #1
2	INPUT #2
3	INPUT #3
4	INPUT #4
5	INPUT #5
6	INPUT #6
7	INPUT #7
8	INPUT #8

CHANNEL INPUTS 9-16:

TASCAM DSUB CHANNEL #	CHANNEL I/P 9-16
1	INPUT #9
2	INPUT #10
3	INPUT #11
4	INPUT #12
5	INPUT #13
6	INPUT #14
7	INPUT #15
8	INPUT #16

INSERT SENDS 1-8:

TASCAM DSUB CHANNEL #	INSERT SENDS 1-8
1	INSERT SEND #1
2	INSERT SEND #2
3	INSERT SEND #3
4	INSERT SEND #4
5	INSERT SEND #5
6	INSERT SEND #6
7	INSERT SEND #7
8	INSERT SEND #8

INSERT SENDS 9-16:

TASCAM DSUB CHANNEL #	INSERT SENDS 9-16
1	INSERT SEND #9
2	INSERT SEND #10
3	INSERT SEND #11
4	INSERT SEND #12
5	INSERT SEND #13
6	INSERT SEND #14
7	INSERT SEND #15
8	INSERT SEND #16

INSERT RETURNS 1-8:

TASCAM DSUB CHANNEL #	INSERT RETURNS 1-8
1	INSERT RETURN #1
2	INSERT RETURN #2
3	INSERT RETURN #3
4	INSERT RETURN #4
5	INSERT RETURN #5
6	INSERT RETURN #6
7	INSERT RETURN #7
8	INSERT RETURN #8

INSERT RETURNS 9-16:

TASCAM DSUB CHANNEL #	INSERT RETURNS 9-16
1	INSERT RETURN #9
2	INSERT RETURN #10
3	INSERT RETURN #11
4	INSERT RETURN #12
5	INSERT RETURN #13
6	INSERT RETURN #14
7	INSERT RETURN #15
8	INSERT RETURN #16

SUBGROUP INSERT SENDS 1-4 AND AUX SENDS:

TASCAM DSUB CHANNEL #	SUBGROUP INSERT SENDS 1-4 AND AUX SENDS
1	SUBGROUP INSERT SEND #1
2	SUBGROUP INSERT SEND #2
3	SUBGROUP INSERT SEND #3
4	SUBGROUP INSERT SEND #4
5	AUX 1 SEND
6	AUX 2 SEND
7	AUX 3L SEND
8	AUX 3R SEND

SUBGROUP INSERT RETURNS 1-4 AND AUXILIARY INPUTS:

TASCAM DSUB CHANNEL #	SUBGROUP INSERT RETURNS 1-4 AND AUX INPUTS
1	SUBGROUP INSERT RETURN #1
2	SUBGROUP INSERT RETURN #2
3	SUBGROUP INSERT RETURN #3
4	SUBGROUP INSERT RETURN #4
5	AUXILIARY INPUT #1 (L)
6	AUXILIARY INPUT #2 (R)
7	AUXILIARY INPUT #3 (L)
8	AUXILIARY INPUT #4 (R)

It is worth noting that, in order to avoid ground loops, the Dsub ground connections are lifted on the MCM20.4 side, leaving the ground paths of your DSUB snakes only acting as shields and preventing any current returns.

SIGNAL FLOW AND BLOCK DIAGRAM (Dsubs omitted for clarity)

CHANNEL 1-8 SECTION

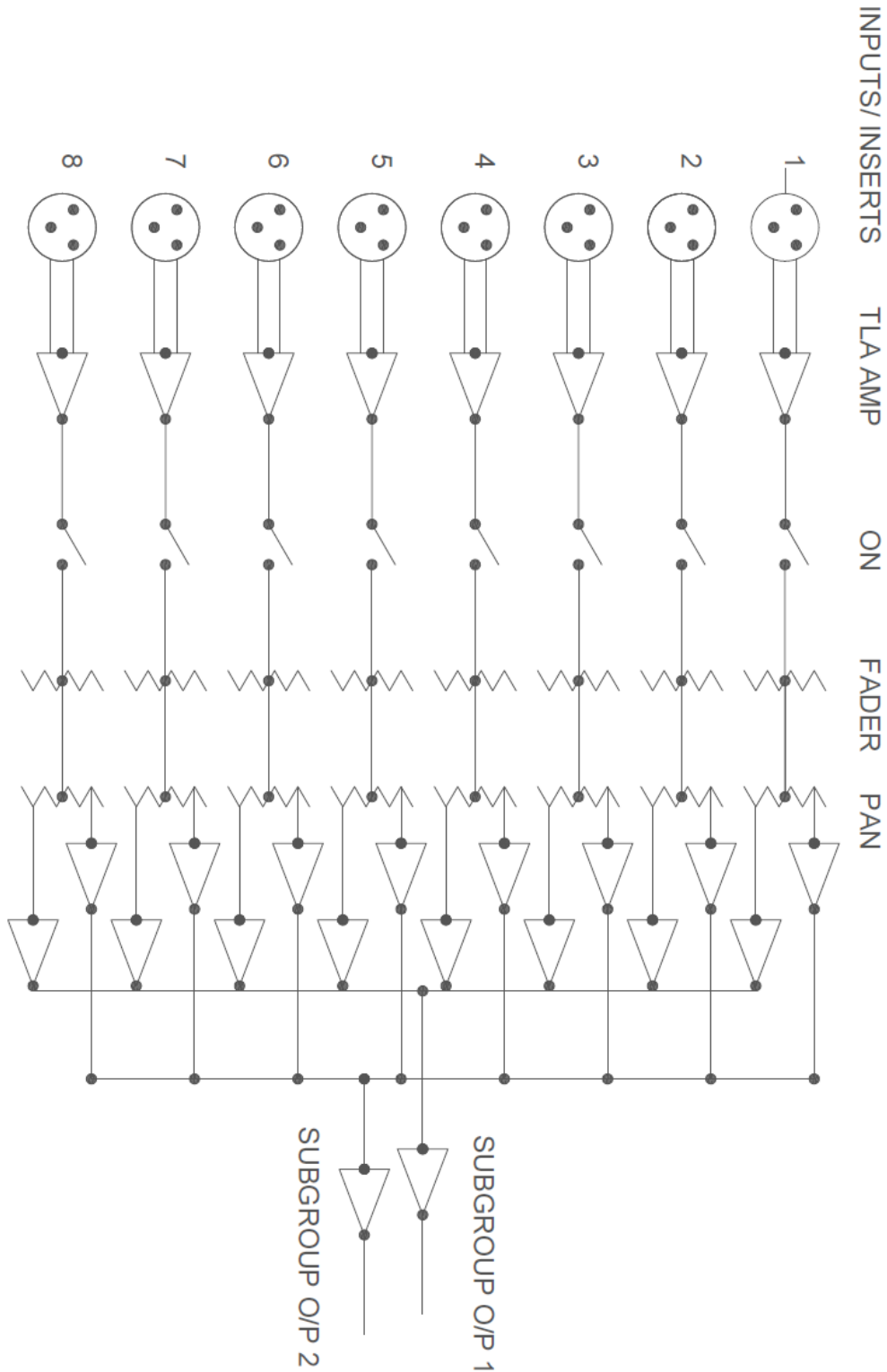

CHANNEL 9-16 SECTION

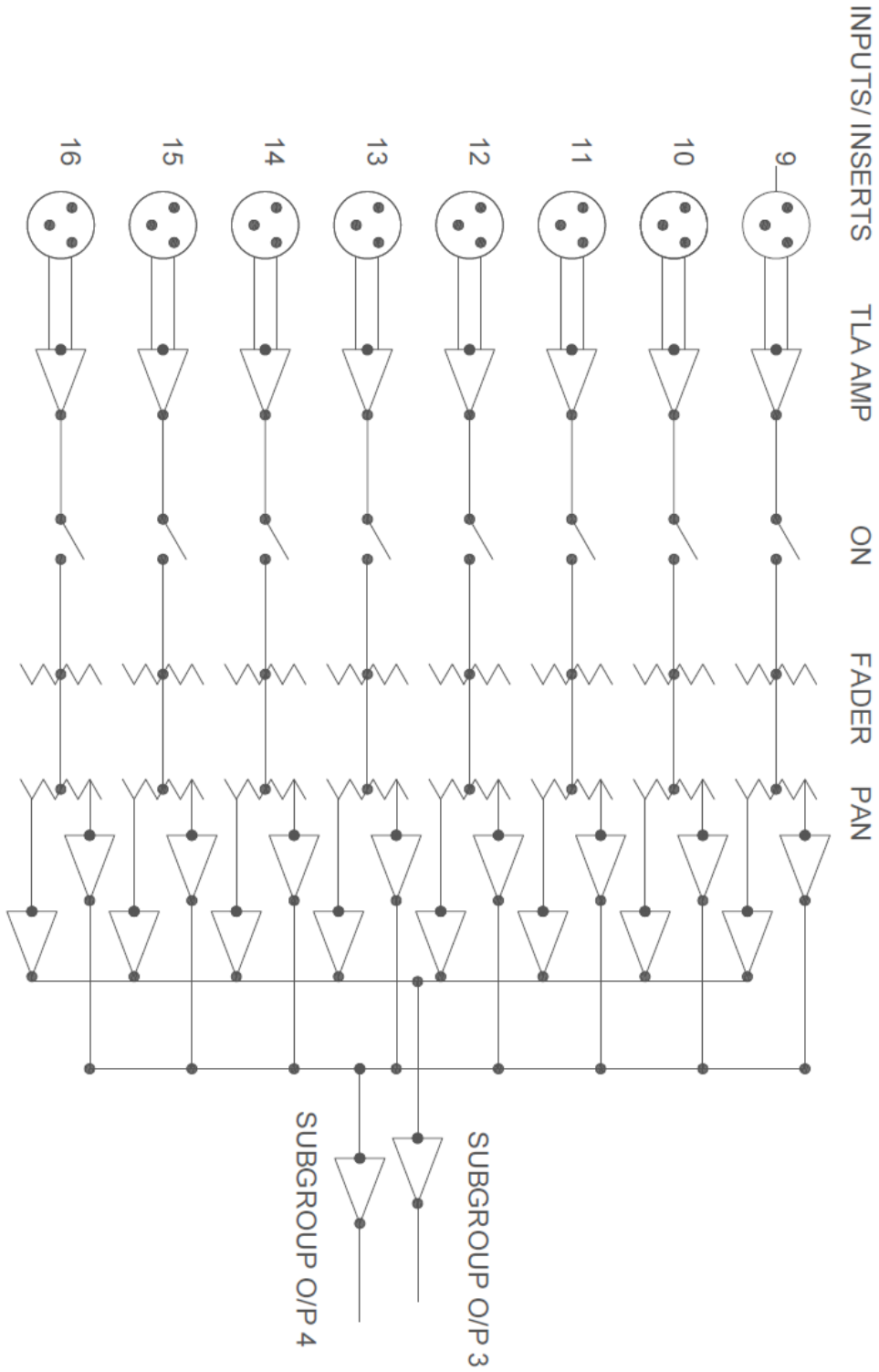

MASTER SECTION

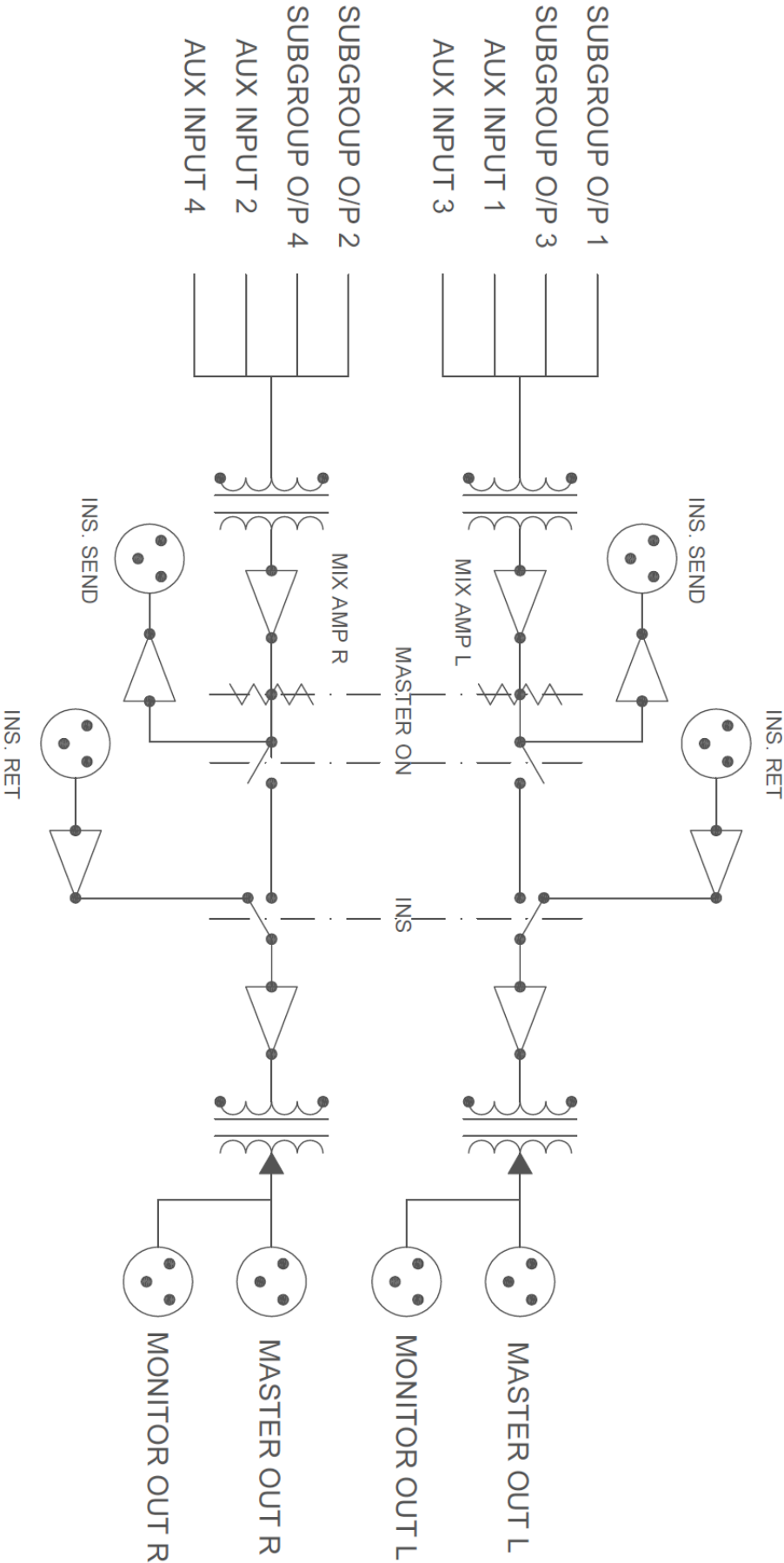

DETAILED AUX SEND SECTION (SAME ALL CHANNELS)

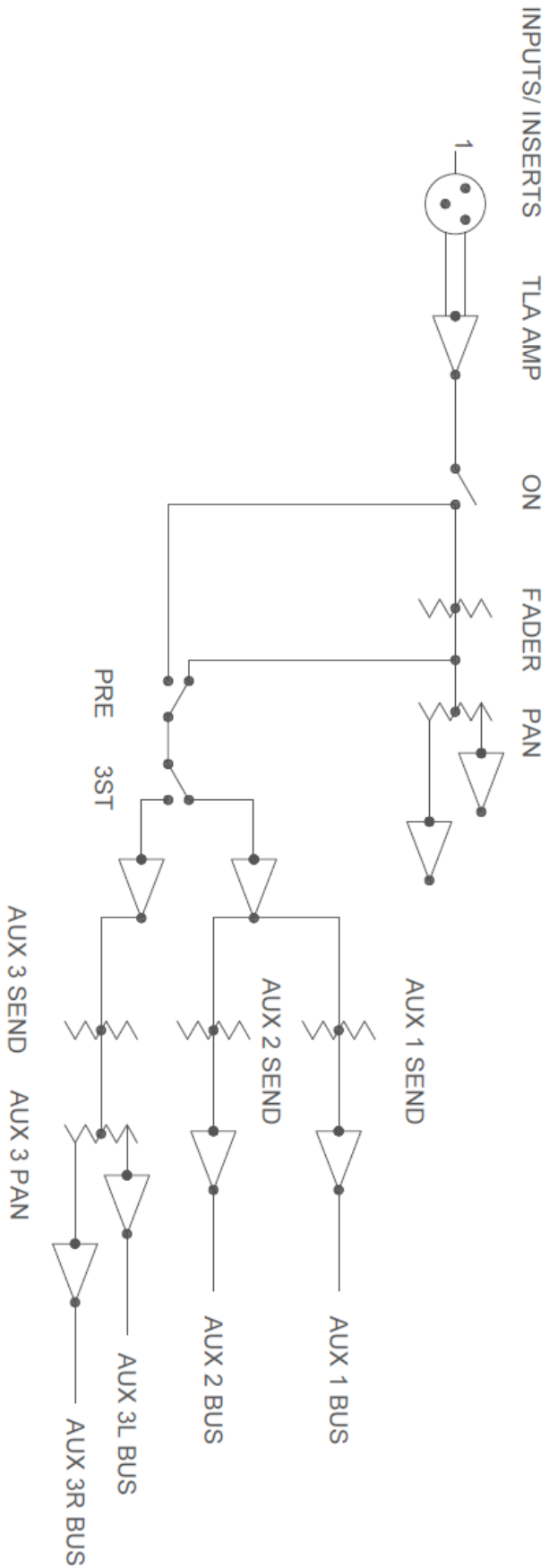

GAIN STRUCTURE

The gain structure in the MCM20.4 is quite simple and intuitive. At the same time, no compromises have been made on the “secondary” inputs and outputs, like the inserts sends and returns and aux sends. Therefore all connections are balanced and all outputs are nominal +4dBu and able to drive 600 ohms.

The gain structure is that all faders up, any input to any output is unity gain.

+4dBu at one channel input, fader all the way up, subgroup fader all the way up, gives +4dBu at the channel and subgroup insert send points, and at the main send and output as well.

+4dBu at the channel or subgroup insert returns will give +4dBu at the main send and output as well.

+4dBu at the main insert return will give +4dBu at the main output.

+4dBu on a channel input, sends pre fader, will give +4dBu at the corresponding aux output.

MCM 20.4 POWER SUPPLY

The MCM range of summing mixers features a hybrid power supply concept, in a very similar way to the On Slot Technology (OST) employed in Heritage’s successful 500 series enclosures range.

An external switching power supply enters the unit by means of a 5 pin XLR connector, where it is further filtered using a PI configuration, using a big common mode choke.

Further, linear regulation stages are used. Different regulation is used for channels and buses, and output stages.

TECHNICAL SPECIFICATIONS

- Channel Input Impedance: Greater than 20 Kohm.
- Maximum channel input level: Greater than +26dBu
- Maximum insert return input level: Greater than +26dBu
- Maximum insert send level: Greater than +27dBu, able to drive 600 ohm.
- Maximum aux send output level: Greater than +27dBu.
- Maximum main output level: Greater than +26dBu into 600ohm.
- Frequency response: ± 0.5 dB 20Hz to 20kHz
- THD + N: Not more than 0.07% from 50 Hz to 10 kHz at +20dBu output (22 Hz to 22 Khz bandwidth) into 600 Ω .
- Noise, all faders up, all subgroups in, measured at the main output, 22Hz to 22Khz: Better than -80dBu



Heritage Audio S.L.

C/ Ardemans, 42. Local.

28028 Madrid

Spain

Tel: +00 34 917 266 189

info@heritageaudio.net

www.heritageaudio.net

* TASCAM and AVID are trademarks of their respective owners and Heritage Audio is in no way affiliated with them.